

# RB-35P

## φ37スパーギヤヘッド (断続タイプ) Spur Gearhead (Intermittent type)

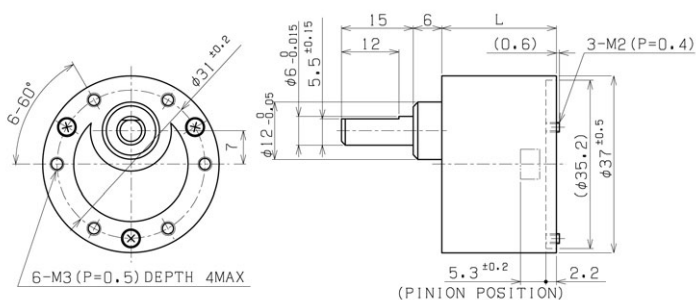

Unit : mm

ピニオン仕様 Pinion Specification	B-208口A		
外径 Outside diameter	6.240		
ピッチ円直径 Pitch circle diameter	5.240		
モジュール Module	0.5		
歯数 No. of teeth	10		
圧力角 Pressure angle	20°		
転位係数 Addendum modification coefficient	0.240		
穴径 Hole diameter	2.0 - 0.020 - 0.040		
対応減速比 Reduction ratio	全減速比 All reduction ratios		

### 仕様 Specifications

型式 ※ Model Number	減速比 Reduction ratio		定格許容トルク Rated torque			段数 Number of stage	効率 Efficiency %	回転方向(モータに対して) Direction of rotation (Drive to output)	長さ(L) Length mm	質量 Mass g
	絶対値 Absolute		mNm	kg · cm	oz · in					
1/ 6	1/	6.00	98.1	1	13.9	2	81	=	19.0	(44.7)
1/ 10	1/	10.00	98.1	1	13.9	2	81	=	19.0	(44.7)
1/ 18	1/	18.00	98.1	1	13.9	3	73		21.5	(49.1)
1/ 25	1/	25.00	98.1	1	13.9	3	73		21.5	(49.1)
1/ 30	1/	30.00	196	2	27.8	3	73		21.5	(49.1)
1/ 50	1/	50.00	294	3	41.7	4	66	=	24.0	(54.9)
1/ 60	1/	60.00	294	3	41.7	4	66	=	24.0	(54.9)
1/ 75	1/	75.00	392	4	55.6	4	66	=	24.0	(54.9)
1/ 90	1/	90.00	392	4	55.6	4	66	=	24.0	(54.9)
1/ 100	1/	100.00	588	6	83.4	4	66	=	24.0	(54.9)
1/ 120	1/	120.00	588	6	83.4	5	59		26.5	(60.0)
1/ 125	1/	125.00	588	6	83.4	5	59		26.5	(60.0)
1/ 150	1/	150.00	588	6	83.4	5	59		26.5	(60.0)
1/ 180	1/	180.00	588	6	83.4	5	59		26.5	(60.0)
1/ 200	1/	200.00	588	6	83.4	5	59		26.5	(60.0)
1/ 250	1/	250.00	588	6	83.4	5	59		26.5	(60.0)
1/ 270	1/	270.00	588	6	83.4	5	59		26.5	(60.0)
1/ 300	1/	300.00	588	6	83.4	5	59		26.5	(60.0)
1/ 400	1/	400.00	588	6	83.4	6	53	=	29.0	(64.1)
1/ 500	1/	500.00	588	6	83.4	6	53	=	29.0	(64.1)
1/ 540	1/	540.00	588	6	83.4	6	53	=	29.0	(64.1)
1/ 600	1/	600.00	588	6	83.4	6	53	=	29.0	(64.1)
1/ 750	1/	750.00	588	6	83.4	6	53	=	29.0	(64.1)
1/ 900	1/	900.00	588	6	83.4	6	53	=	29.0	(64.1)
1/ 1,000	1/	1000.00	588	6	83.4	6	53	=	29.0	(64.1)
1/ 1,500	1/	1500.00	588	6	83.4	7	48		31.5	(68.3)
1/ 1,800	1/	1800.00	588	6	83.4	7	48		31.5	(68.3)
1/ 3,000	1/	3000.00	588	6	83.4	7	48		31.5	(68.3)

標準品 Standard

※ 御注文の際は減速比を呼称願います。

特注品 Custom-made

When placing an order, please specify the reduction ratio.

### テクニカルデータ Technical Data

種類 Type	スパー Spur	ステンレス Stainless steel
出力軸 Output shaft	スリーブ Sleeve	
出力軸ベアリング Bearing at output		
ラジアルガタ Radial play (mm)	≤ 0.1	
スラストガタ Axial play (mm)	≤ 0.35	
使用温度範囲 Operating temperature range (°C)	- 10°C ~ + 60°C	

### 組合せ Combination

種類 Type	モータ Motor				ギヤードモータ Gear Motor		エンコーダ Encoder		
	型式 Model Number	外径 (mm) Diameter	ページ Page	長さ (mm) Length	ページ Page	型式 Model Number	ページ Page	長さ (mm) Length	
コアード Iron Core	FMA x x	36.0	14	34.4+L	107				
コアード Iron Core	N x x x	35.4	14	28.4+L	107				
コアード Iron Core	NCB x x	27.8	14	33.9+L	108				
コアード Iron Core	N x x x LJ	36.0	14	45.4+L	108				

上記データは参考値です

The above data is for reference only.